



# BRUSH TRUCK

Midwest Fire Equipment & Repair Company manufactures high-quality fire apparatus to serve your community for decades. Operating with a neighborly style and Midwestern values, our skilled team of professionals work to design the most versatile, high value fire apparatus to aid firefighters in the protection of life and property.



## Standard Features:

- Aluminum Body Construction
- Multiple Storage Compartments
- 100-700 GPM Engine-Driven Pump Options
- NFPA Compliant Warning Lights & Striping
- Emergency Siren & Speaker
- 150-500 Gallon Poly Tank with Optional Foam Cell
- NFPA Warning Lights and Striping
- Hose Reel Options
- Rear Receiver Hitch & Tow Ring
- Suspension Lift Kit & Super Single Tires

## Options:

- Foam Systems Available
- Multiple Compartment Configurations
- Front & Rear Winch Applications
- Remote Monitor
- Heavy-Duty Grille Guard
- Shelving & Slide-Out Tray Options
- Front & Rear Spray Bars
- Scene Lighting
- Ford & Dodge Chassis
- Loose Equipment Mounting
- Multiple Customized Options Available



info@MidwestFire.com • 901 Commerce Road • P.O. Box 524 • Luverne, MN 56156  
MidwestFire.com • 1.800.344.2059

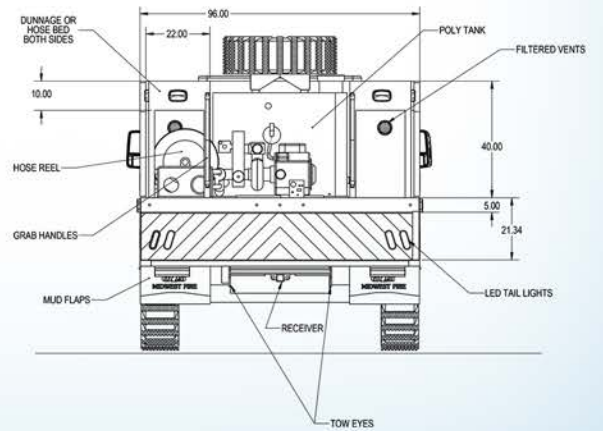
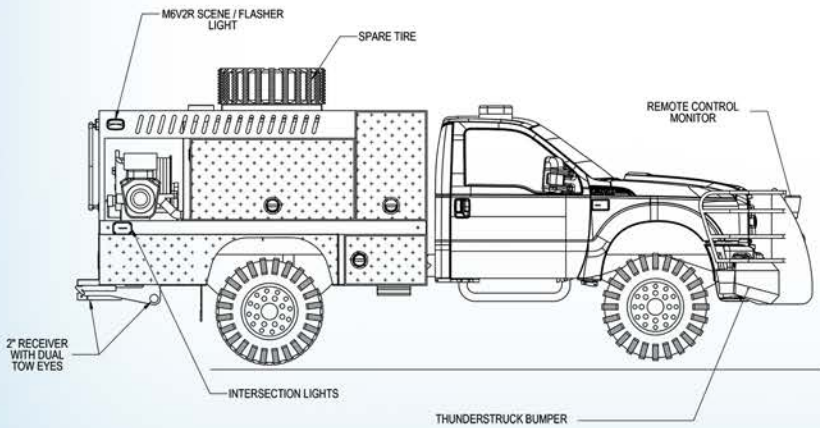
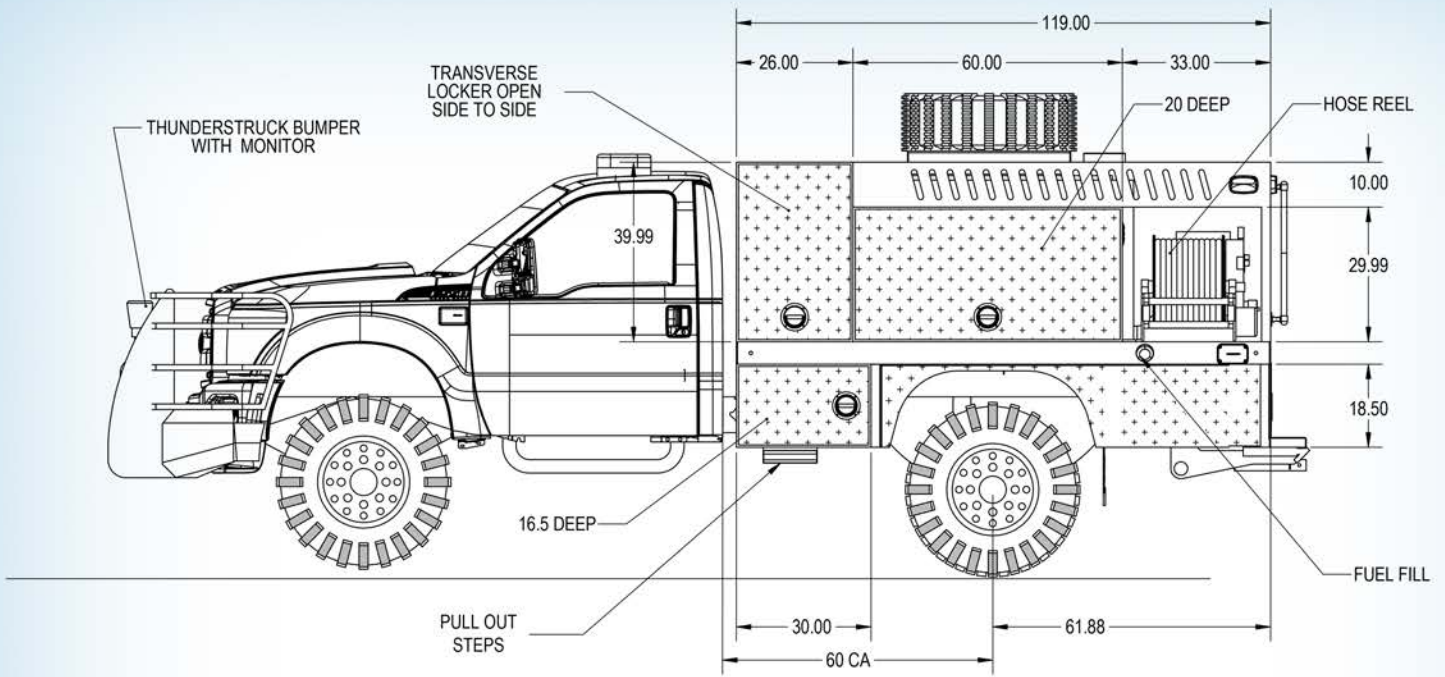

# BRUSH TRUCK

